

Wilkhahn

Graph

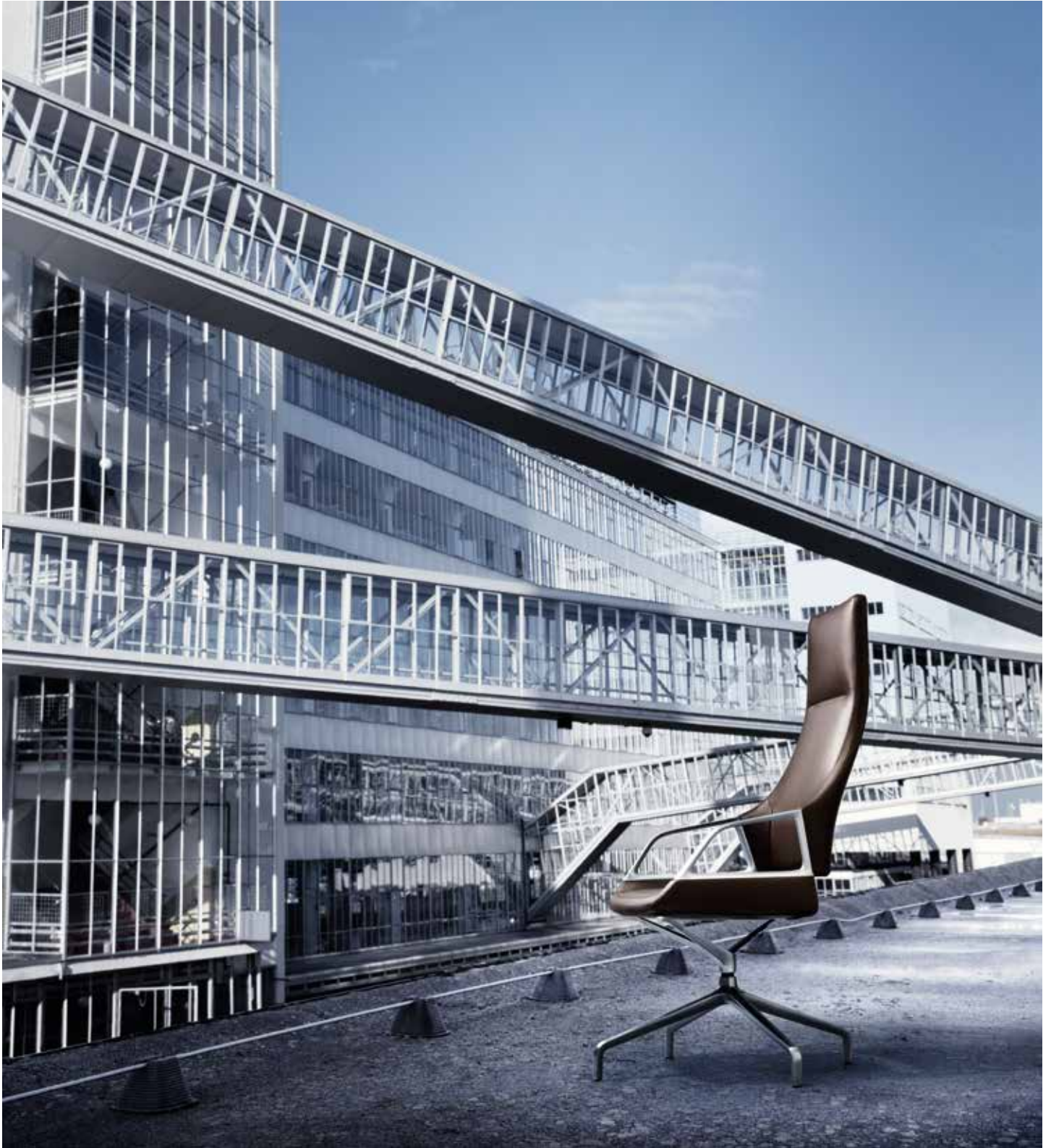



Where form and function go hand in hand – the Graph conference range.

Graph is the epitome of superb design for conference rooms. Its name already indicates the multi-award-winning graphic-like aesthetic which has created new benchmarks in its field. Because the characteristic form is not just reflected in the chairs, but also in the table layouts. The results are immediately impressive spaces that project seamless, high-quality design.

The chairs look transparent, but very appealing nevertheless. Straight edges and fluid lines, flat and curved surfaces, soft and hard features intermingle so that seat body and frame merge into one. The same applies to the tables, where the lines of the sloping table legs continue on into the aluminium underframes. The result is a frame of apparently weightless stylishness that appears to consist of one piece. Whatever the layout of Graph furniture, the end result is always a pleasing one.

The cutting-edge design and uncompromising premium quality of the finishes, materials and craftsmanship indicate that conferences are taken seriously. And the exclusive seated comfort is an exceptional experience for anyone.



Perfection down to the last detail.



Sit down and take pleasure in the look and feel of the chair. Its outstanding comfort is the result of the first-class upholstery with its covered, padded and cushioned seat- and backrest-frames. Combined with its innovative suspension, the result is pleasant, three-dimensional flexibility which stimulates both body and mind.

Considering the chair's impeccable style, it's almost a given that no screws are visible on the armrests. Or that the shapes and finishes on the frame are perfectly formed and crafted. Or that the stitching on the sophisticated covers precisely mirrors the chair's elegant line. The same goes for the haptics. Your hands will like touching especially important areas like the armrests or the gently tapering table edges.

The furniture's design is distinctive, but is easy to coordinate with specific interior-design concepts. Black- or white-coated frames, high-quality fabric covers, or glass table tops coated on the bottom to match can lend a special touch to deliberately modern backdrops. Where interiors require a certain gravitas, chrome-plated finishes, classy leather covers and select wood veneers are the right solutions.

Bright chrome-plated, matt-polished, or coated aluminium frames, table leaves made of opaque toughened glass coated on the bottom, or MDF panels optionally coated or with wood veneers, or the exquisite fabric and leather collection for the covers, provide a whole host of design ideas.



Graph is at home anywhere where expressing corporate and brand values is vital.







With a variety of designs, materials and table formats, Graph can adapt to different room sizes and interior-design concepts.

One form – a variety of models.

The distinctive form of the chairs stems from the core design concept of cutting through a seat shell horizontally and vertically to reassemble it in a different way. The armrests become the key connection between the backrest frame and seat which is affixed at the front flexibly on a Y-shaped fork and supported at the back by a leaf spring in the middle.

At the same time this method produced a modular structure which spawned the functional requirements of the different models. The chair comes with a medium-high or high backrest, with stylishly narrow or larger glides, or with castors to make it easy to shift, or even with five-star bases if height-adjustable versions are chosen. The chair models, table formats, finishes and covers have all the right options for hard or soft floorings, for impromptu meetings, prestigious conference rooms, or exclusive executive offices.







Leadership. Alone or as part of a team.

What area of a company says more about its culture than its conference rooms or executive offices? So it's comforting to know that the Graph chairs' first-class design and excellent comfort impress across the board. They cut a dash at a large conference table, around a small meeting table, or in an executive office. The designers created a slightly flatter, five-star base with castors for the executive chair. So they left room for a height-adjustable column to make the seating height precision-adjustable. The height-adjustment mechanism is subtly integrated into the Y-shaped seat bearer and the classy lever resembles a long cocktail spoon.

The executive chair also comes with the typical feeling of lightness and sophistication that stand the range apart. Because the mix of permanently elastic connecting parts at the front, the leaf spring at the back, and the luxuriously suspended, upholstered frame, make the chair a supremely comfortable and flexible place to sit. And other special features of this first among equals also include two backrest heights, just like the conference chairs.



Fundamental variety.

Table sizes range from 120 x 120 to 230 x 780 centimetres. The formats include round tables, as well as compact and long oval shapes which are based on squares and triangles. The drawings show table-leg positions, panel segments, underframes, possible single-table portals (only in wood-based panels) and cable channels for a greater number of cables and control devices for modern multi-media equipment.

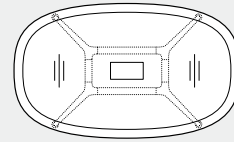

6 people – 120 x 200 cm

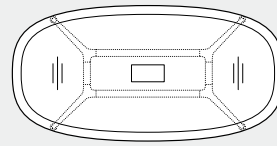

6 people – 120 x 240 cm

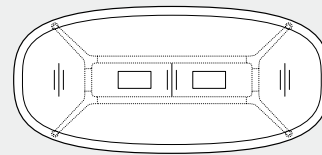

8 people – 130 x 280 cm

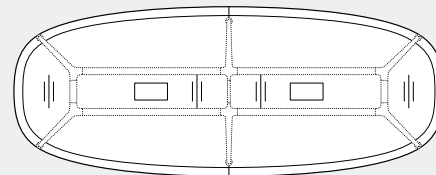

10 people – 150 x 380 cm

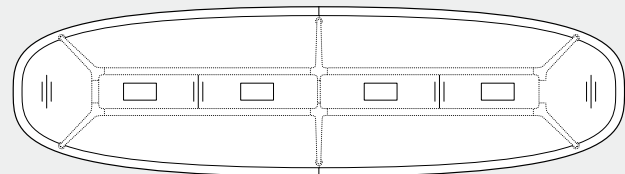

14 people – 150 x 540 cm

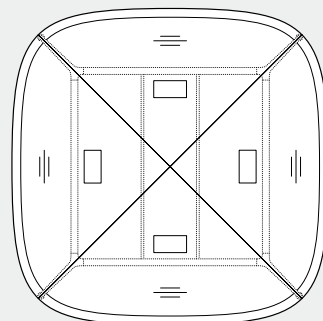

12 people – 280 x 280 cm

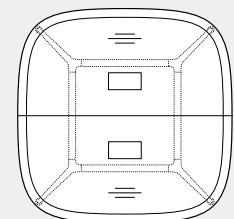

8 people – 190 x 190 cm

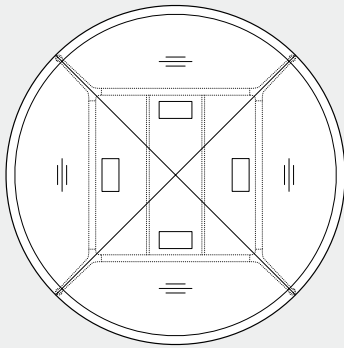

12 people – Ø 300 cm

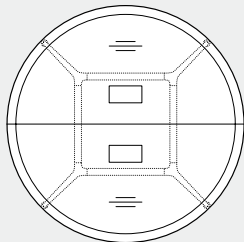

8 people – Ø 210 cm

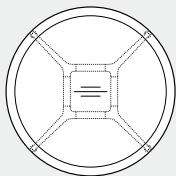

4 people – Ø 150 cm

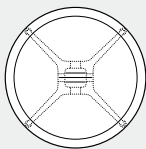

4 people – Ø 125 cm

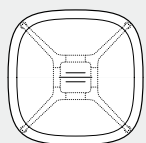

4 people – 120 x 120 cm

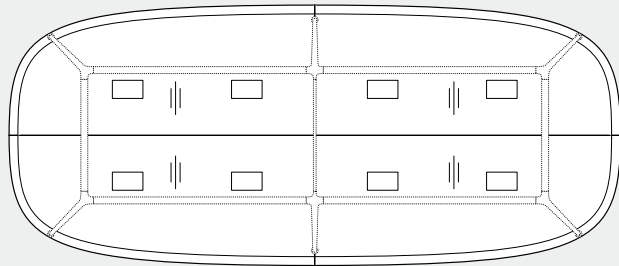

16 people – 230 x 540 cm

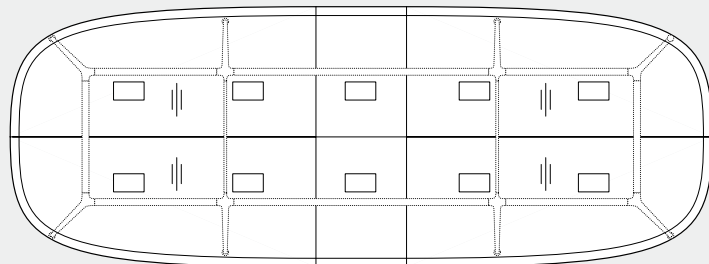

18 people – 230 x 620 cm

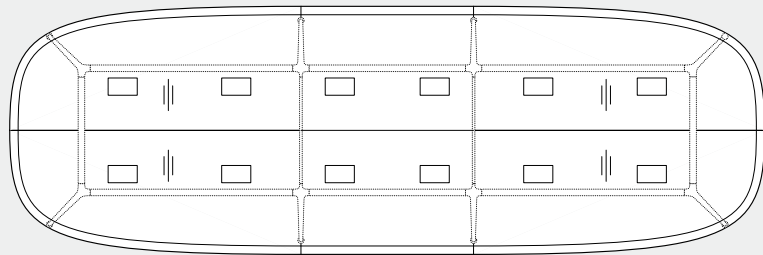

20 people – 230 x 700 cm

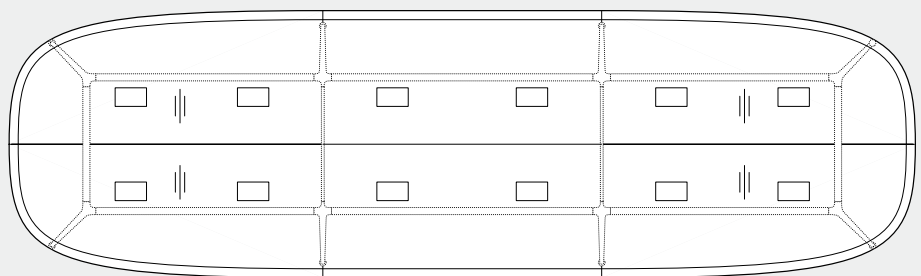

22 people – 230 x 780 cm

Technical features.

Aesthetic and comfort-enhancing features are included, right down to the last detail. The single table portals (only in wood-based panels) to access slots for multi-media equipment are virtually invisible. Similarly to the portals, the cut-out sections have solid, chamfered wood lipping and gas lifts cushion the flaps. It's hard to think of a better way of integrating multi-media equipment.

The same applies underneath the table top. The cable channels are flush-mounted underneath the table top and between the underframes and can therefore be stowed away and disappear from view. As a result, even when wired for today's multi-media equipment, nothing detracts from the table's style and appeal. If required, we can supply the tables and table systems with multi-media equipment, or prepare cut-out sections, single table portals and cable channels.

Consistent perfection, even underneath the table top.
Ease of use and an uncluttered feel.



Graphic-like precision.

How do you translate the typical atmosphere of a traditional conference room to the future and develop a new, classic piece of furniture at the same time? Right at the beginning of the four-year project, Markus Jehs and Jürgen Laub decide to dispense with traditional rules of finding a form.

Their methodical approach was one of deconstruction. First of all, a unitary seat shell was cut through along its horizontal and vertical axis. The idea was to look at how these elements could be adapted and then reassembled in a different way. The result? A harmonious, but nevertheless distinctive look, where first-class form and innovative function go hand in hand. It's quite simply a timeless statement where both look and feel triumph.

Markus Jehs and Jürgen Laub

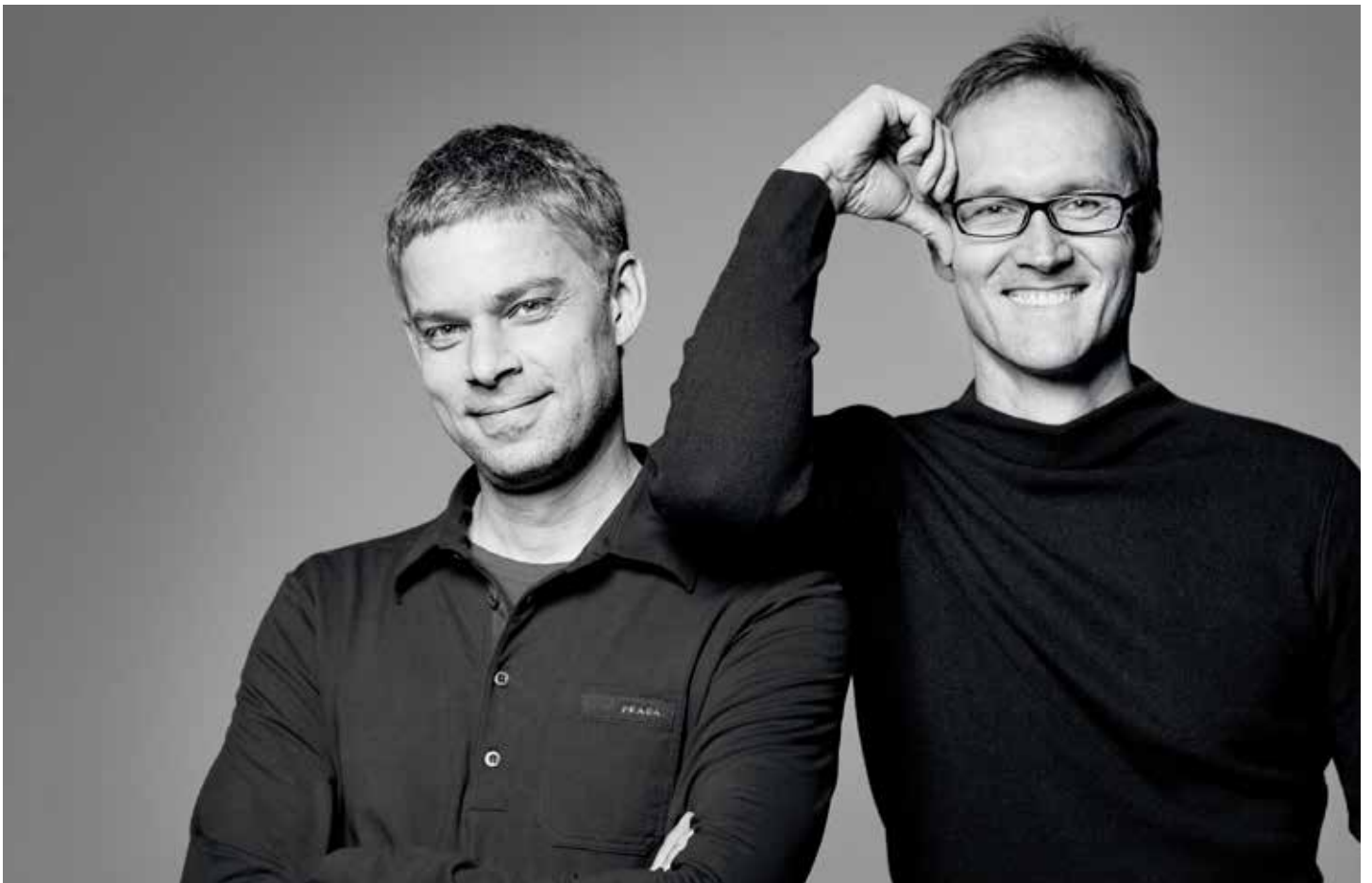



"During the development phase, we managed to find the ideal balance between aesthetics and engineering. And in the end Graph is exactly what we had dreamt of at the beginning".

Markus Jehs and Jürgen Laub

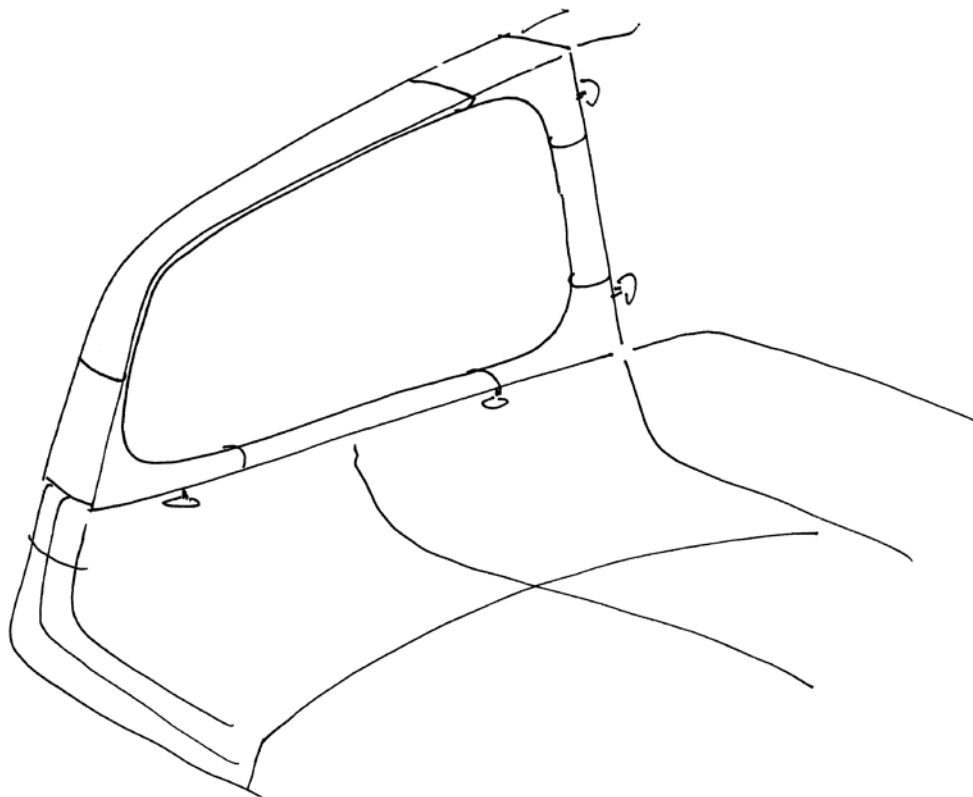



Wilkhahn Germany

Wilkening + Hahne GmbH+Co. KG, Fritz-Hahne-Straße 8, 31848 Bad Münder

Wilkhahn worldwide

Australia, Belgium, China, España, France, Great Britain, Hong Kong, Japan, Maroc, Nederland, Österreich, Schweiz, Singapore, South Africa, United Arab Emirates, United States of America.

wilkhahn.com

Graph chair



Graph table

